

Hypac C530A

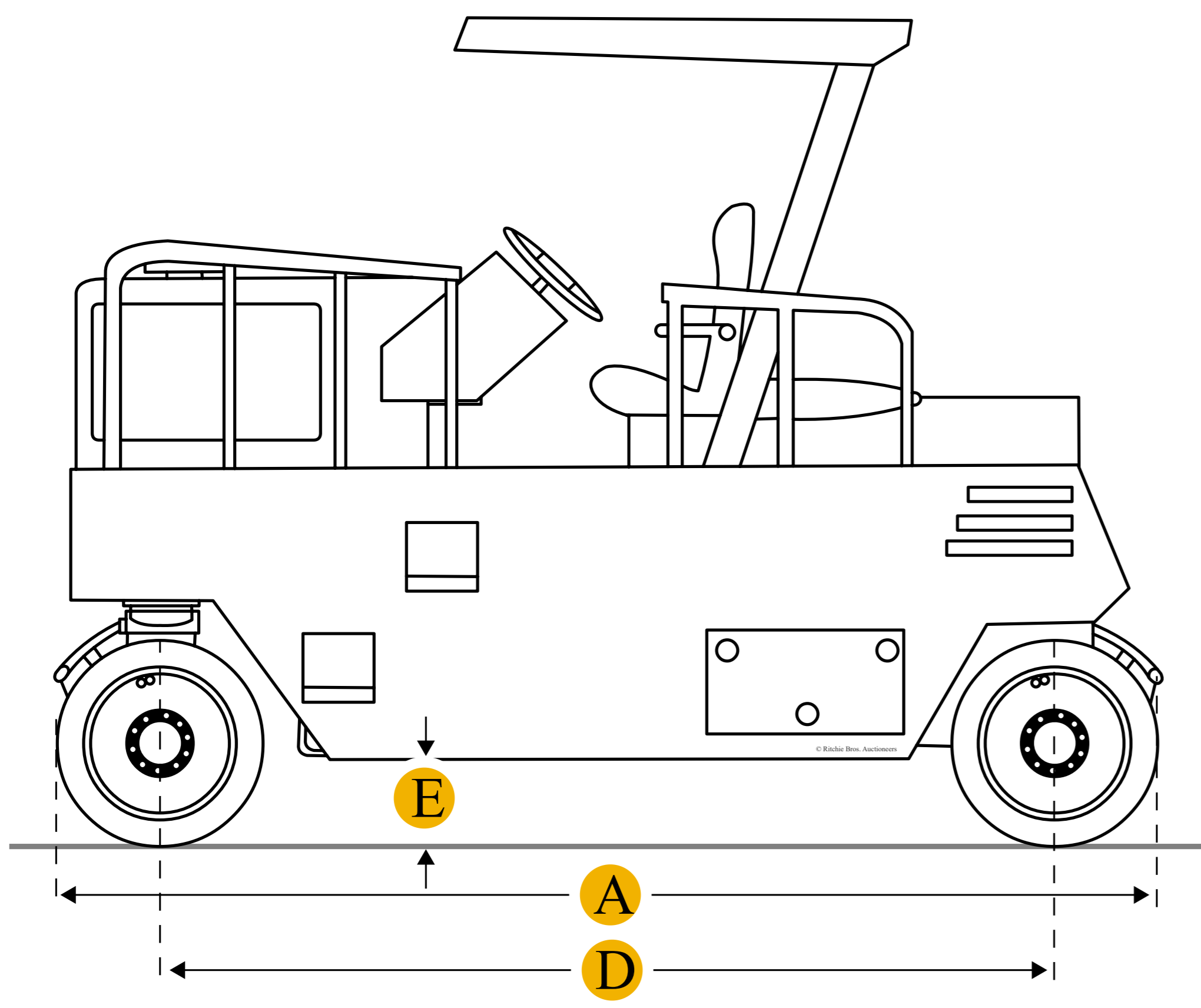
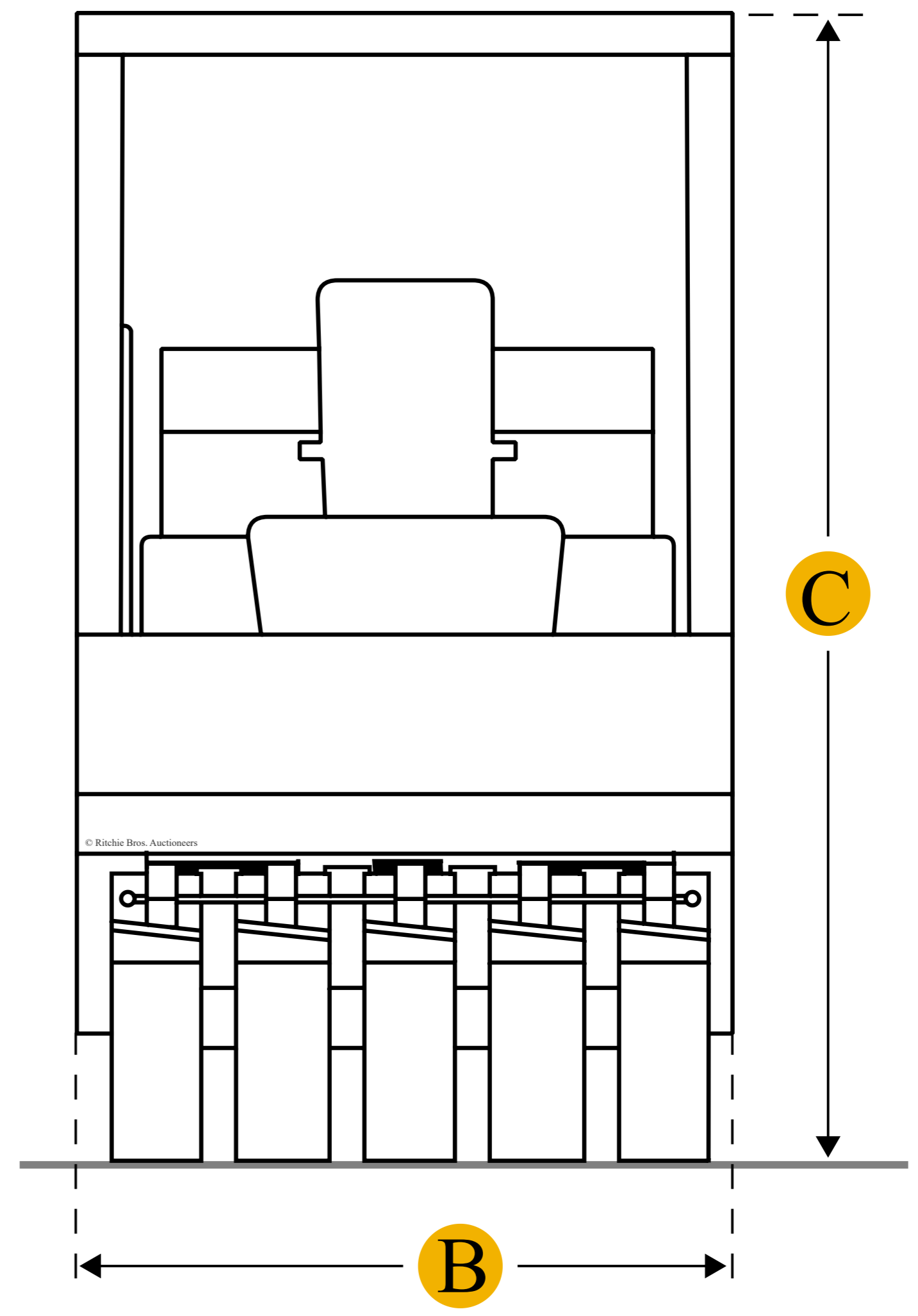
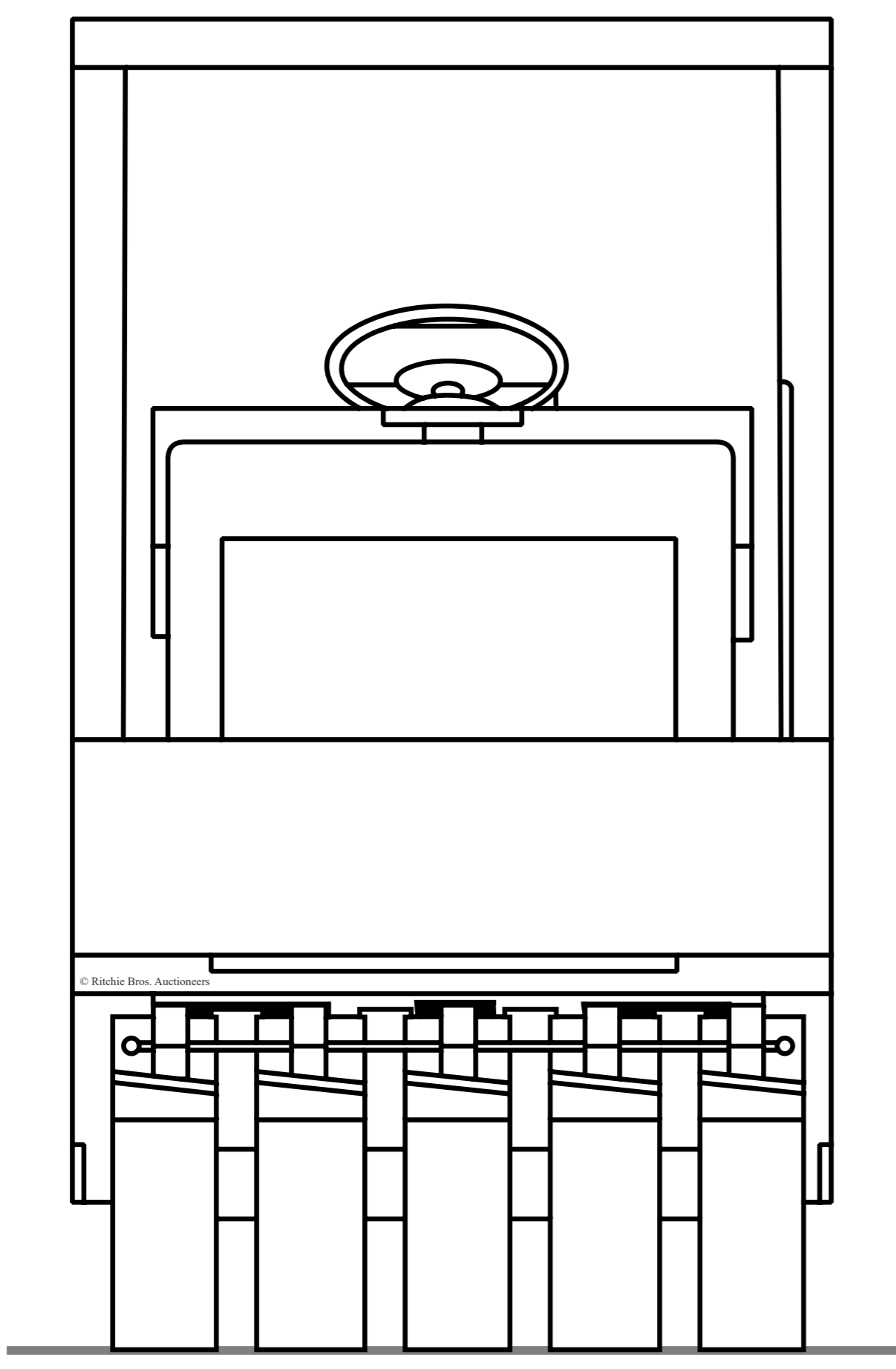

Units

Imperial

Metric

Dimensions

Dimensions

A Overall Length	4445 mm
B Overall Width	1727 mm
C Height To Top Of Rops	2870 mm
D Wheelbase	2235 mm
E Ground Clearance	330 mm

Specifications

Engine

Number Of Cylinders	4
Engine Make	2347
Engine Model	4B3.3TA
Gross Power	63.4 kw
Power Measured @	2600 rpm

Operational

Fuel Capacity	114 L
Engine Oil Capacity	9.5 L
Hydraulic System Fluid Capacity	108 L
Water Spray Tank Fluid Capacity	568 L
Max Speed	25 km/h
Operating Voltage	12 V

Weights

Operating Weight - Standard	4524.6 kg
Operating Weight - Max Ballast	12247 kg
Average Weight Per Wheel - Max Ballast	1360.8 kg

Tires

Number Of Tires - Front	4
Number Of Tires - Rear	5
Standard Tire Size	7.50x15, 12ply
Oscillation Angle	10 degrees
Wheel Track/Tire Overlap	12.5 mm